



THERMAL ELECTRIC ELEMENTS
AUSTRALIA



Air Conditioning Industry

Product	Page No.
Stainless Steel Finned Air Heaters	4.1
AMS Type	4.2
APS Type	4.3
ASS Type	4.4
Finless Air Heaters	4.5
Air Finned Heater Banks	4.6
Controls for the Air Conditioning Industry	4.7

4.1

Air Conditioning Industry

Finned Air Heaters - For Corrosive Atmosphere ACFB - ACFS

CONSTRUCTION:

Thermal Incoloy sheathed tubular elements are fitted with continuous brass (ACFB) or stainless steel fins (ACFS), ensuring excellent heat transfer to air in duct heating.

Finned air heaters are manufactured to order and come in a variety of shapes and sizes. ACF type elements are used where a non-corrosive heater is required, eg marine applications.

INSTALLATION:

For best results, finned type heaters should be evenly spaced, at 50mm centres with alternate rows staggered to expose heaters to the in-flowing air. For duct mounting, 3/8" BSP bushes are provided complete with washers and locknuts.

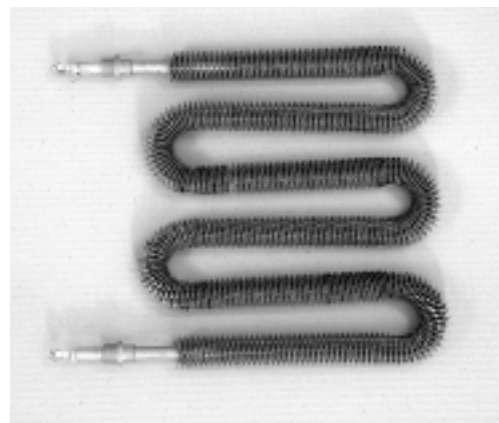
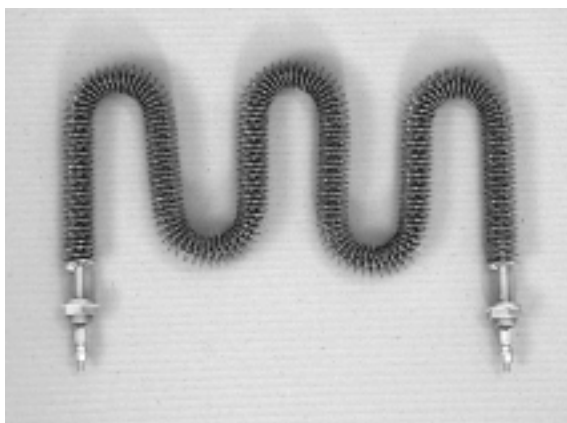

Air Conditioning Industry

Stainless Steel Finned Air Heaters - AMS Type

SHEATH WATTS DENSITY
124kW/in² (80W/in²)

Fin and sheath total 11kW/m² (7W/in²)

OPERATING TEMPERATURES:

Maximum permissible temperature of element when operating is 400°C.

Minimum air velocity of 3 metres/sec through face area of duct is recommended if operated in accordance with AS1668 Part 1.

CONSTRUCTION:

Continuous spiral Stainless Steel fin fitted to 8mm dia Stainless Steel sheathed tubular element.

Dia over fin 27mm.

Finning pitch 6.4mm.

FINISH:

Stainless Steel.

MOUNTING:

Bushes 16mm conduit thread by 13mm long.

Clearance hole of 18mm required.

Nuts and washers included.

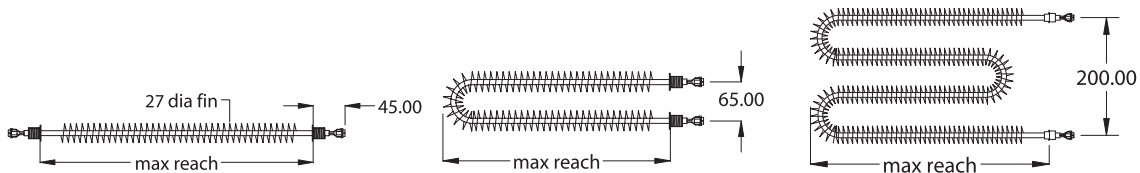

STRAIGHT LENGTH		
Cat No.	Watts	Max Reach
AMS075S	750	334
AMS100S	1000	415
AMS125S	1250	486
AMS150S	1500	574
AMS175S	1750	655
AMS200S	2000	722
AMS250S	2500	886
AMS300S	3000	1055
AMS350S	3500	1213
AMS400S	4000	1373
AMS450S	4500	1522
AMS500S	5000	1686

U'FORM		
Cat No.	Watts	Max Reach
AMS075U	750	164
AMS100U	1000	204
AMS125U	1250	240
AMS150U	1500	284
AMS175U	1750	324
AMS200U	2000	358
AMS250U	2500	440
AMS300U	3000	524
AMS350U	3500	603
AMS400U	4000	683
AMS450U	4500	758
AMS500U	5000	840

W'FORM		
Cat No.	Watts	Max Reach
AMS125W	1250	133
AMS150W	1500	155
AMS175W	1750	175
AMS200W	2000	188
AMS250W	2500	233
AMS300W	3000	275
AMS350W	3500	315
AMS400W	4000	355
AMS450W	4500	388
AMS500W	5000	433

All dimensions are given in millimetres and elements are rated at 240V. Special sizes, voltages and wattages manufactured to suit your requirements.

4.3

Air Conditioning Industry

Stainless Steel Finned Air Heaters - APS Type

SHEATH WATTS DENSITY
43.5kW/in² (28W/in²)

Fin and sheath total 2.8kW/m² (1.8W/in²)

OPERATING TEMPERATURES:

Element surface temperature will not exceed 400°C in still air at 20°C if operated in accordance with AS1668 Part 1 .

CONSTRUCTION:

Continuous spiral Stainless Steel fin fitted to 11.1mm dia Stainless Steel sheathed tubular element.

Dia over fin 30mm.

Finning pitch 5.1mm.

FINISH:

Stainless Steel.

MOUNTING:

Bushes 16mm conduit thread by 13mm long.

Clearance hole of 18mm required.

Nuts and washers included.

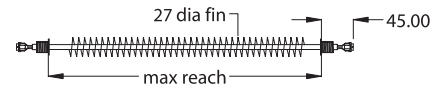

Straight Length		
Cat No.	Watts	Max Reach
APS075S	750	597
APS100S	1000	764
APS125S	1250	931
APS150S	1500	1098
APS175S	1750	1265
APS200S	2000	1433
APS250S	2500	1767
APS300S	3000	2102
APS350S	3500	2436
APS400S	4000	2770
APS450S	4500	3105
APS500S	5000	3437

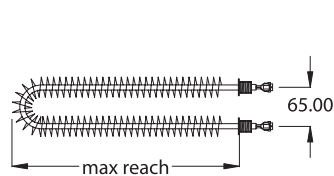

'U' FORM		
Cat No.	Watts	Max Reach
APS075U	750	298
APS100U	1000	381
APS125U	1250	465
APS150U	1500	548
APS175U	1750	632
APS200U	2000	716
APS250U	2500	883
APS300U	3000	1050
APS350U	3500	1217
APS400U	4000	1384
APS450U	4500	1552
APS500U	5000	1718

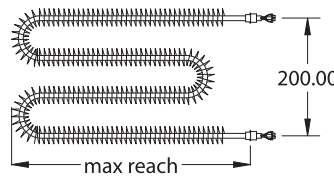

'W' FORM		
Cat No.	Watts	Max Reach
APS075W	750	164
APS100W	1000	205
APS125W	1250	243
APS150W	1500	286
APS175W	1750	331
APS200W	2000	373
APS250W	2500	456
APS300W	3000	537
APS350W	3500	623
APS400W	4000	707
APS450W	4500	788
APS500W	5000	874

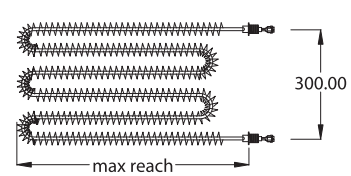

TRIPLE 'U' FORM		
Cat No.	Watts	Max Reach
APS175T	1750	237
APS200T	2000	266
APS250T	2500	324
APS300T	3000	383
APS350T	3500	441
APS400T	4000	499
APS450T	4500	558
APS500T	5000	616

All dimensions are given in millimetres and elements are rated at 240V. Special sizes, voltages and wattages manufactured to suit your requirements.

Air Conditioning Industry

Stainless Steel Finned Air Heaters - ASS Type

SHEATH WATTS DENSITY
60kW/in² (39W/in²)

Fin and sheath total 4.3kW/m² (2.8W/in²)

OPERATING TEMPERATURES:

Maximum permissible temperature of element when operating is 400°C.
Minimum air velocity of 1.0 metre/sec through face area of duct recommended if operated in accordance with AS1668 Part 1 .

CONSTRUCTION:

Continuous spiral Stainless Steel fin fitted to 11.1mm dia Stainless Steel sheathed tubular element.
Dia over fin 30mm.
Finning pitch 5.1mm.

FINISH:

Stainless Steel.

MOUNTING:

Bushes 16mm conduit thread by 13mm long.
Clearance hole of 18mm required.
Nuts and washers included.

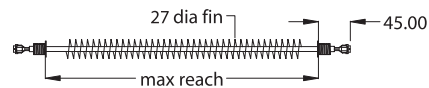

Straight Length		
Cat No.	Watts	Max Reach
ASS075S	750	455
ASS100S	1000	564
ASS125S	1250	695
ASS150S	1500	815
ASS175S	1750	920
ASS200S	2000	1055
ASS250S	2500	1277
ASS300S	3000	1495
ASS350S	3500	1718
ASS400S	4000	1948
ASS450S	4500	2220
ASS500S	5000	2473
ASS600S	6000	2908

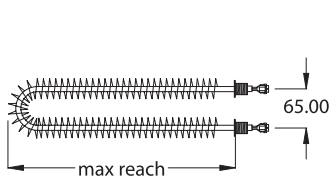

'U' FORM		
Cat No.	Watts	Max Reach
ASS75U	750	226
ASS100U	1000	281
ASS125U	1250	346
ASS150U	1500	406
ASS175U	1750	459
ASS200U	2000	526
ASS250U	2500	638
ASS300U	3000	747
ASS350U	3500	858
ASS400U	4000	973
ASS450U	4500	1109
ASS500U	5000	1235
ASS600U	6000	1453

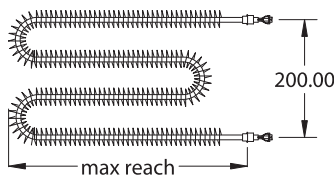

'W' FORM		
Cat No.	Watts	Max Reach
ASS100W	1000	154
ASS125W	1250	184
ASS150W	1500	218
ASS175W	1750	240
ASS200W	2000	278
ASS250W	2500	334
ASS300W	3000	384
ASS350W	3500	439
ASS400W	4000	500
ASS450W	4500	569
ASS500W	5000	632
ASS600W	6000	738

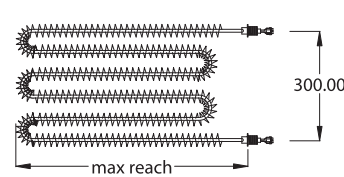

TRIPLE 'U' FORM		
Cat No.	Watts	Max Reach
ASS250T	2500	239
ASS300T	3000	276
ASS350T	3500	315
ASS400T	4000	357
ASS450T	4500	403
ASS500T	5000	447
ASS600T	6000	593

All dimensions are given in millimetres and elements are rated at 240V. Special sizes, voltages and wattages manufactured to suit your requirements.

4.5

Air Conditioning Industry

Finless Type - ACU

CONSTRUCTION:

Thermal Incoloy sheathed tubular elements are designed to heat air flows in circular and rectangular ducts or circulated air in industrial ovens.

They can be used as radiant heaters and resistive load banks.

INSTALLATION:

3/8" BSP bushes are designed to provide fitting and rigid support of the elements.

For bush mounting 18mm holes are required.

These elements are made to customer's specifications in straight, U form, W form or Triple U form.

Standard unfinned heaters come with 3/8" bsp brass bushes and stirrup terminals
if they do not suit your application we can modify our product to suit your requirements

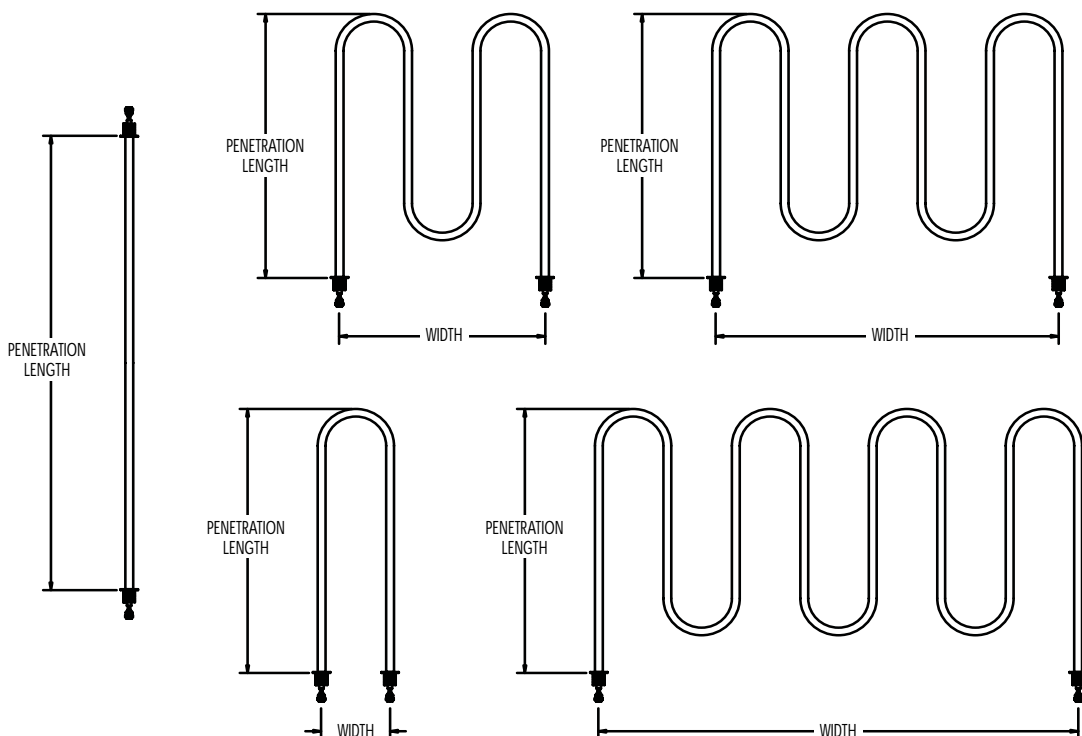

Air Conditioning Industry

Air Finned Heater Banks

Complete heater banks can be manufactured to suit your requirements. The elements are staggered within the terminal box to obtain maximum heat dissipation from element fins to air.

These heater banks can also be used as RESISTIVE LOAD BANKS for generator 'start ups'.

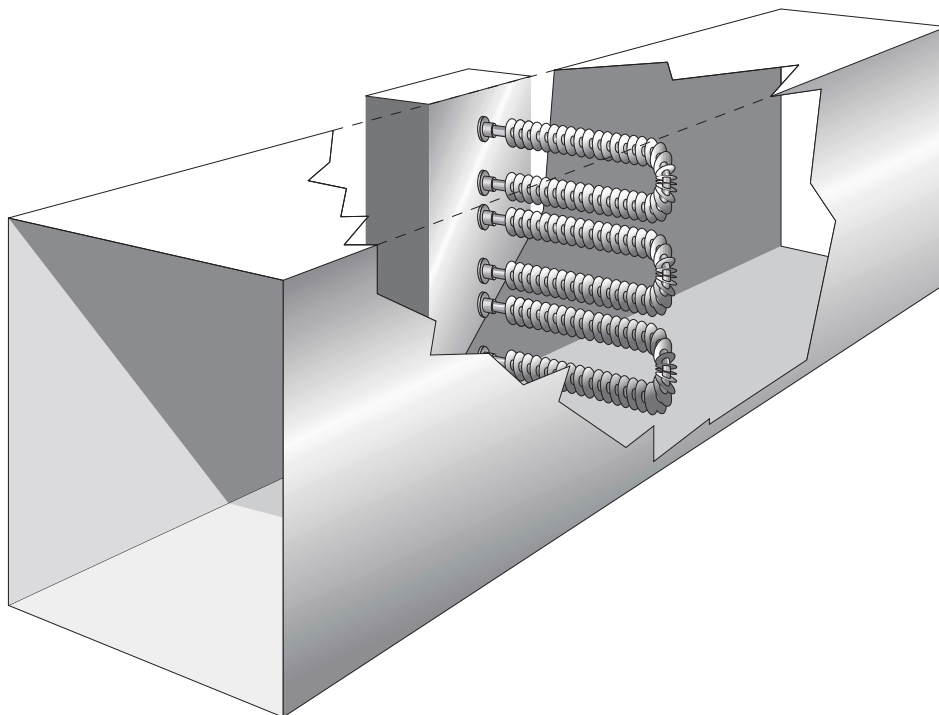

4.7



Air Conditioning Industry

Controls for the Air Conditioning Industry

In accordance with AS1668 Part 1, temperature controllers and air pressure switches are required to eliminate overheating and possible premature failure of duct heaters.

Over Temperature Controllers:

An over temperature controller is a thermally operated switch, designed to provide protection when it's capillary tube is heated above a preset cut out temperature. This could be caused by an accidental cutting of the air flow. Over temperature controllers come in both manual and automatic reset. The units are fail safe - if capillary is ruptured, the contacts open automatically.

Switch Action	Current Rating	Reset	Cut out Temperature Range	Image
Manual Reset	16 Amp	Manual	Up to 120°C	
Adjustable Manual Reset	20Amp	Manual	60°C to 150°C	

Product	Current Rating	Operating Pressure & Temperature Range	Image
Air Pressure Switch	15 Amp Resistive at 125V.A.C.	.05" + .02" - .02" to 12.0" WC - 40°C to + 82°C	